

Anschluß Schema FBI, IP66, kMMP

Connection Table Forced Ventilation Unit, IP66, kMMP

Schéma de branchement Ventilation Forcée FBI, IP 66, kMMP

Schema di collegamento FBI IP 66, kMMP

Esquema de conexión FBI IP66, kMMP



Bg. 56 – 355 RBK-UL

Stand: Mai 04

- D** **Achtung!** Der Motor wurde gegen Körperschluß geprüft mit 1.500 V gem. VDE! Bei einer Wiederholungsprüfung max. 1.000 V anlegen um einen Wicklungsschaden zu vermeiden!
- GB** **Attention!** This motor is tested against body current with 1.500 V following VDE! If a further test is carried out at client, it must not exceed 1.000 V in order to prevent winding damage!
- F** **Attention!** Ce moteur a subi un test d'isolement sous une tension de 1.500 V d'après VDE! Chaque nouveau test doit être effectué sous une tension max. de 1.000 V afin de ne pas endommager le bobinage!
- I** **Attenzione!** Il motore è stato mantenuto alla prova di corto circuito con 1.500 V secondo VDE! In caso di ripetizione della prova non usare più di max. 1.000 V per evitare danno dal avvolgimento!
- E** **Atencion!** El motor ha estado mantenido a la prueba de cortocircuito con 1.500 V según VDE! En caso de repetición de la prueba, usar como max. 1.000 V para evitar una avería del bobinado!

Drehstrommotor in 1-Phasen „Steinmetz“ Schaltung
Three phase motor in single phase connection acc. to „Steinmetz“
Moteur asynchrone triphasée en couplage „Steinmetz“
Motore trifase in collegamento „Steinmetz“ in 1-fase
Motor trifásico en connexion „Steinmetz“ en 1-fase

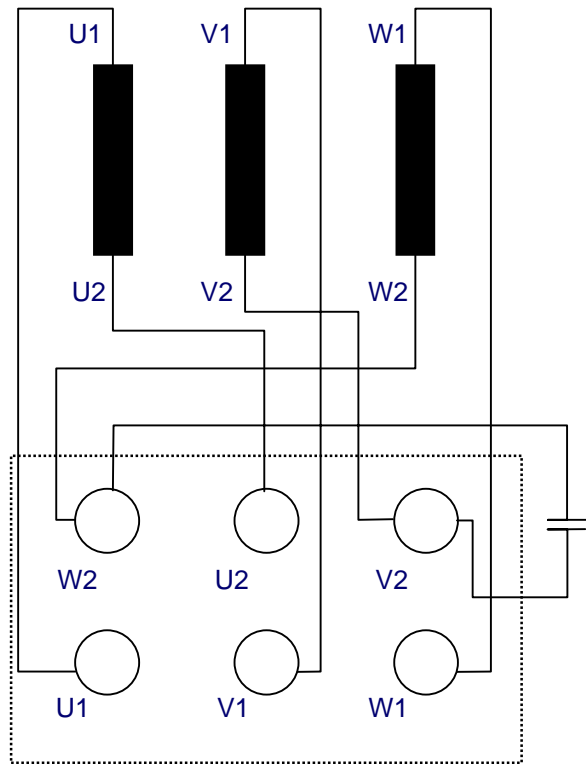

MBK / capacitor / condensateur / condensatori / condensatore

Drehstrommotor
Three phase motor
Moteur asynchrone triphasée
Motore trifase
Motor trifásico

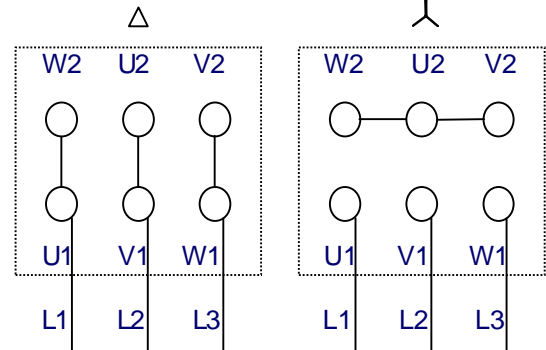
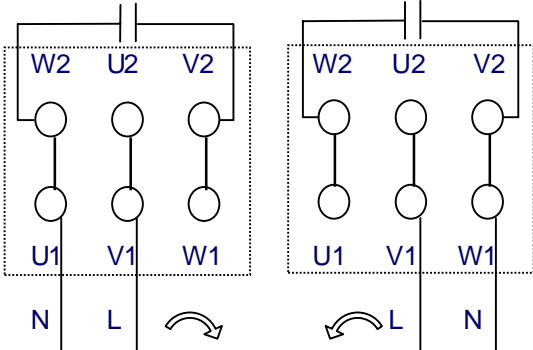
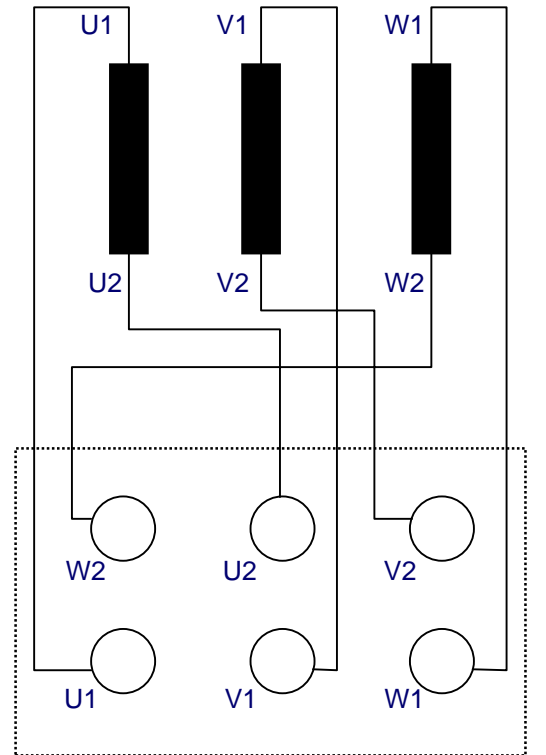

U1	No. 1	Blau	blue	bleue	azzurro	azul
V1	No. 2	Weiß	white	blanche	bianco	blanco
W1	No. 3	Schwarz	black	noire	nero	negro
U2	No. 4	Braun	brown	brune	marrone	marrón
V2	No. 5	Grau	grey	gris	grezzo	gris
W2	No. 6	Rot	red	rouge	rosso	rojo



Grün-gelb green-yellow verde-jaune verde-giallo verde-amarillo

Kurt Maier Motor-Press GmbH

Birkenweg 18 * D-37589 Kalefeld

☎ (05553) 99 01-0 * 📠 (05553) 49 67 * ✉ E-mail: wm@kmmp.de * <http://www.kmmp.de>

