



8901 E. PLEASANT VALLEY ROAD  
 INDEPENDENCE, OHIO 44131-5508  
**TELEPHONE:** (1) 216-642-1230 • **FAX:** (1) 216-642-6037  
**E-MAIL:** tachs@avtron.com • **WEB:** www.avtronencoders.com

# Encoder Instructions

## MODEL AV115

115mm FLANGE MOUNT  
 MODULAR

### DESCRIPTION

The Avtron AV115 is a modular, two piece incremental encoder (also known as a tachometer or rotary pulse generator). It provides a two phase, A Quad B frequency (pulse) output, with complements. The AV115 mounts on a 115mm C-Face, also known as a B-Flange.

Because the AV115 is modular, there are no bearings or couplings required. This, combined with the latest magneto-resistive (MR) sensor technology, allows the AV115 to provide superior mechanical performance and increased reliability.

An Avtron AV115 can be configured with one or two independent outputs. Each output has six signals: (A, B) 90° out of phase, with complements ( $\bar{A}$ ,  $\bar{B}$ ). A marker pulse with complement (Z,  $\bar{Z}$ ) is also provided.

Output resolution on the AV115 is determined by the sensor only. Unlike older models, any PPRs can be mixed and matched. Selection of the rotor is based only on the shaft mounting requirements (and not PPR).

#### NOTE

**Special option 002 selects an alternate PPR code definition. Example: A-128 PPR with option code 000. A\*-1270 PPR with option code 002.**

### INSTALLATIONS

Refer to the back page of these instructions for outline and mounting dimensions. Axial float or endplay must be less than  $\pm 1.27$ mm.

In preparation for installing the Model AV115 pulse generator, it is first necessary to clean both the accessory motor shaft and the mounting face. These surfaces must be inspected and any paint, burrs, or other surface imperfections removed.

### Equipment Needed for Installation

Provided	Optional	Not Provided
AV115 Stator/Housing Socket Hd Cap Screw M10 x 20mm (4) AV115 Rotor Socket Set Screw M4 x 6mm (2) or Pre- installed cam screw Thread locker (blue)	Extended Shaft Cover w/ Screws 6-32 x 0.31" (4) Lock Washers Thru Shaft Cover w/ V-Ring Seal and Silicone Lubricant	Phillips Screwdriver 2mm Hex Wrench (T-Handle Style for Thru- Shaft Rotors >70mm) 3mm Hex Wrench 8mm Hex Wrench

Installation procedures should be performed only by qualified personnel. Safety precautions must be taken to ensure machinery cannot rotate and all sources of power are removed during installation.

### ROTOR INSTALLATION

The motor shaft must project at least 16mm from the motor face. For set screw rotors only: Apply anti-seize compound to the motor shaft. For all rotors: Slide the rotor onto the shaft with the marking "This side out" facing out (away from the motor face). The rotor centerline must match the sensor centerline. To accomplish this, use the rotor locating gauge (A28503) and slide the rotor onto the shaft until it is in the proper position as shown in Figure 1. If a gauge is not available, use the stator housing alignment grooves as show in Figure 3.

### STANDARD CAM SCREW ROTOR INSTALLATION

Turn the cam screws of the rotor in the directions shown on the rotor to engage the cams. Tighten to 5.6 - 6.8 N-m (See Figure2) using the 3mm hex wrench. Total cam screw rotation will be less than one turn.

### AV115 PART NUMBERS AND AVAILABLE OPTIONS

Model	Housing Type	Shaft Size (Thru Shaft Rotor)	Cover Style	Line Driver	Single/Left Output (PPR)	Right Output (PPR)	Connector	Modifications
AV115	1- Single Output 2- Dual Output	0- Non. Std. Shaft Size X- None  Thru Shaft Rotor (Metric) D2- 10mm DK- 38mm DA- 11mm DL- 42mm D3- 12mm DN- 45mm DB- 14mm DM- 48mm DC- 15mm DP- 52mm DD- 16mm DR- 55mm D4- 18mm DS- 60mm DE- 19mm MU- 65mm* DF- 24mm MV- 70mm* DG- 28mm MW- 75mm* DH- 30mm MY- 80mm* DJ- 32mm MZ- 85mm* DJ- 36mm	E- Extended Shaft Cover F- Flat Cover T- Flat Thru- Hole Cover with Shaft Seal (Seal not available on shafts larger than 75mm)	6- 5-24V in/out 8- 5-24 V in, 5-15 V out high power 9- 5-24V in, 5V out	0- Non. R- 512 Std. S- 600 C^A- 50 V- 900 F- 60 J- 960 G- 100 Y- 1024 H- 120 Z- 1200 A- 128 A^A-1270 B^A-150 3- 2000 L- 240 4- 2048 N- 256 5- 2500 P- 300 D- 4096 E- 360 8- 4800 B- 480 9- 5000 Q- 500	C^A- 50 J- 960 F- 60 Y- 1024 G- 100 Z- 1200 H- 120 A^A-1270 A- 128 3- 2000 L- 240 4- 2048 N- 256 D- 4096 P- 300 B- 480 E- 360 R- 512 S- 600 X- None V- 900	P- 10 Pin EPIC Industrial w/ Plug G- 10 Pin Industrial w/ Plug (Northstar pinout) W- 3 Ft. Cable, Sealed Z- 3 Ft. Cable w/ EPIC Industrial	000- No Modification 002^A-select alternate PPR assignment code 004- Add Housing Drain (single output only) 9xx- Special Cable Length, xx=length in feet

\* Cam Screw Rotor only  
10mm-60mm

^ To specify this PPR,  
also specify modifica  
tion code 002

FIGURE 2

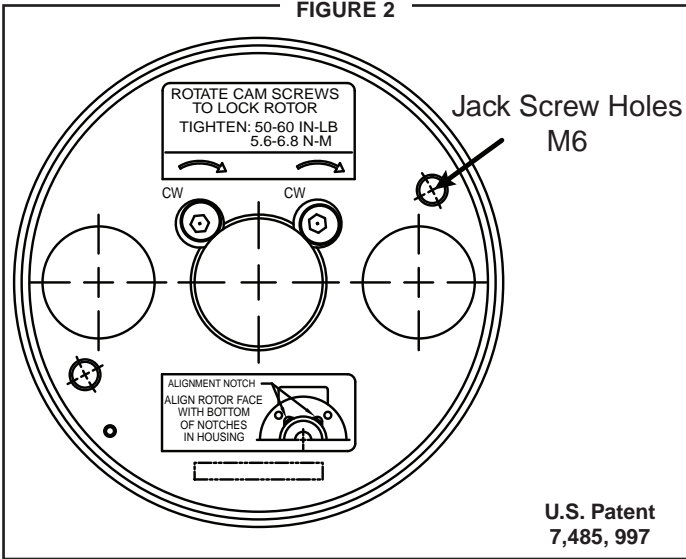

**CAUTION**

Do not adjust the cam screws before motor shaft mounting; bottoming out the screws, or backing them out excessively, can lead to insufficient shaft holding force. Thread locker is preapplied on the cam screws.

**LARGE BORE SET SCREW ROTOR INSTALLATION**

Apply thread locker to the rotor set screw holes, preferably from

the inside of the rotor bore before mounting. Tighten the rotor set screws to 2 N-m using the 2mm T-handle hex wrench.

**CAUTION**

Use only a T-handle or torque hex wrench to tighten set screws; using a right angle wrench will not provide enough holding force, and the rotor may slip.

**STATOR HOUSING INSTALLATION**

The stator housing is attached to the motor using four socket head cap screws M10 x 0.5 x 20mm long, locating on a 150mm bolt circle. Longer bolts (not included), are required for sandwich installation between a motor and a brake. Install the four mounting bolts using thread locker and torque to approximately 27 to 40 N-m using the 8mm T-handle hex wrench.

**VERIFY ROTOR LOCATION**

To ensure the rotor is properly located on the shaft: remove the back cover if factory-preinstalled, and verify that the outer face of the rotor is at the same depth as the alignment grooves, using a straight edge tool. (Figure 3)

**CAUTION**

Do not use silicone sealants or caulk of any kind on the motor or encoder face; these can cause misalignment or sensor scraping damage. The AV115 electronics are fully sealed; water may enter and leave the rotor area as needed. A drain hole option is available if frequent moisture buildup is expected.

**SPECIFICATIONS**

**ELECTRICAL**

- A. Operating Power (Vin)
  - 1. Volts .....5-24 VDC
  - 2. Current.....100mA, each output, no load
- B. Output Format
  - 1. 2Q & Comp .....A,  $\bar{A}$ , B,  $\bar{B}$  (differential line driver)
  - 2. Marker.....1/Rev, Z,  $\bar{Z}$
- C. Signal Type.....Incremental, Square Wave, 50  $\pm$ 10% Duty Cycle.
- D. Direction Sensing..... $\odot$ A leads  $\odot$ B for CW rotation as viewed from the back of the tach looking at the non-drive end of the motor.
- E. Phase Sep.....15% minimum
- F. Frequency Range.....0 to 165,000 Hz
- G. PPR.....8-5000
- H. Line Driver Specs.....See table
- I. Connectors.....See connector options on page 1
- J. Integral LED Indicator....GREEN: power on, unit ok. RED: alarm on

**MECHANICAL**

- A. Rotor Inertia: .....12-25kg-cm<sup>2</sup>
- B. Acceleration:.....5000 RPM/Sec. Max.
- C. Speed: .....5400 RPM Max.
- D. Weight: .....0.9kg to 1.36kg.
- E. Sensor to Rotor
  - Air Gap (nominal):.....0.76mm
  - Tolerance:.....0.38mm
- F. Rotor Axial Tolerance .. $\pm$ 1.27mm

**ENVIRONMENTAL**

Solid cast aluminum stator and rotor  
 Fully potted electronics, protected against oil and water spray  
 Use "W" cable option on IP66/67 applications  
 V-Ring seals provided on through shaft covers  
 Operating Temperature: .....-40 to 100°C, 0-100% condensing humidity

**LINE DRIVER OPTIONS**

Electrical Specifications		LINE DRIVER OPTIONS			Units
		6	8	9	
Input Voltage		5-24	5-24	5-24	VDC
Nom Output Voltage		5-24	5-15	5	VDC
Line Driver		7272	4125	7272	
Output Resistance Typ		13	3	13	ohms
Maximum Peak Current		1500	3000	1500	mA
Maximum Average Current		120	350	120	mA
Voh Typ		V <sub>IN</sub> -1	V <sub>IN</sub> -1, max 15V out	V <sub>IN</sub> -1	VDC
Vol Typ		0.5	0.4	0.5	VDC
Cable Drive Capacity		1000' @ 5V 500' @ 12V 200' @ 24V	1000'	1000'	feet
Protection	Reverse Voltage	yes	yes	yes	
	Short Circuit	yes	yes	yes	
	Transient	yes	yes	yes	
Alarm	+V(out)	Output voltage equal to input voltage.			
	Alarm*	Open collector, normally off, goes low on alarm, sink 100mA max, 50VDC max			
	LED	Green=power on, Red=Alarm			
Marker		One per revolution. Pulse width approximately 1/128 of a revolution			

\*Alarm not available on connector option "G" (Northstar™ compatible pinout)

FIGURE 1

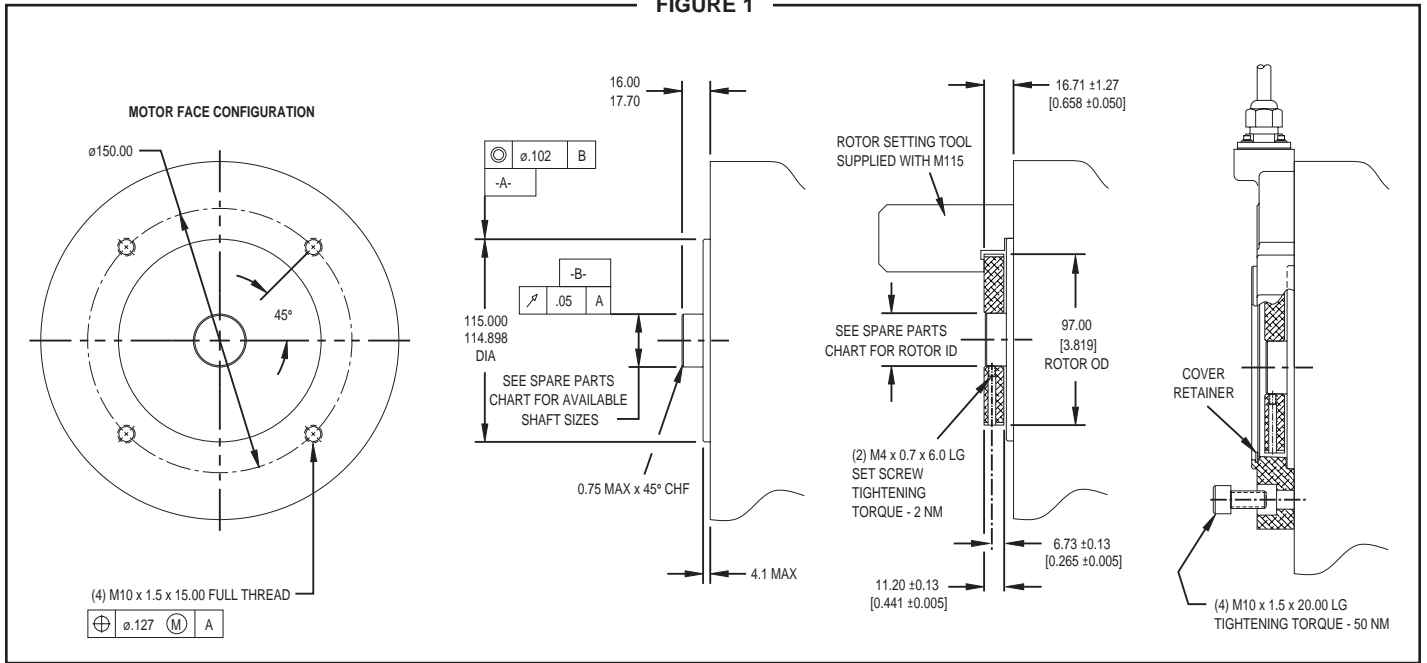

FIGURE 3

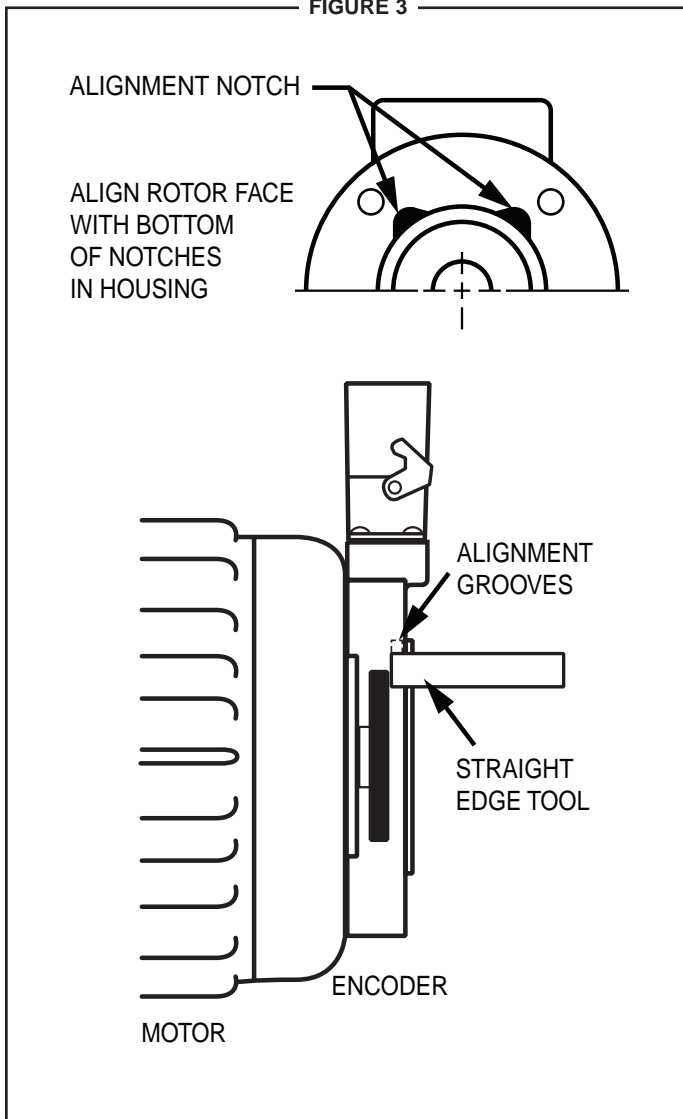
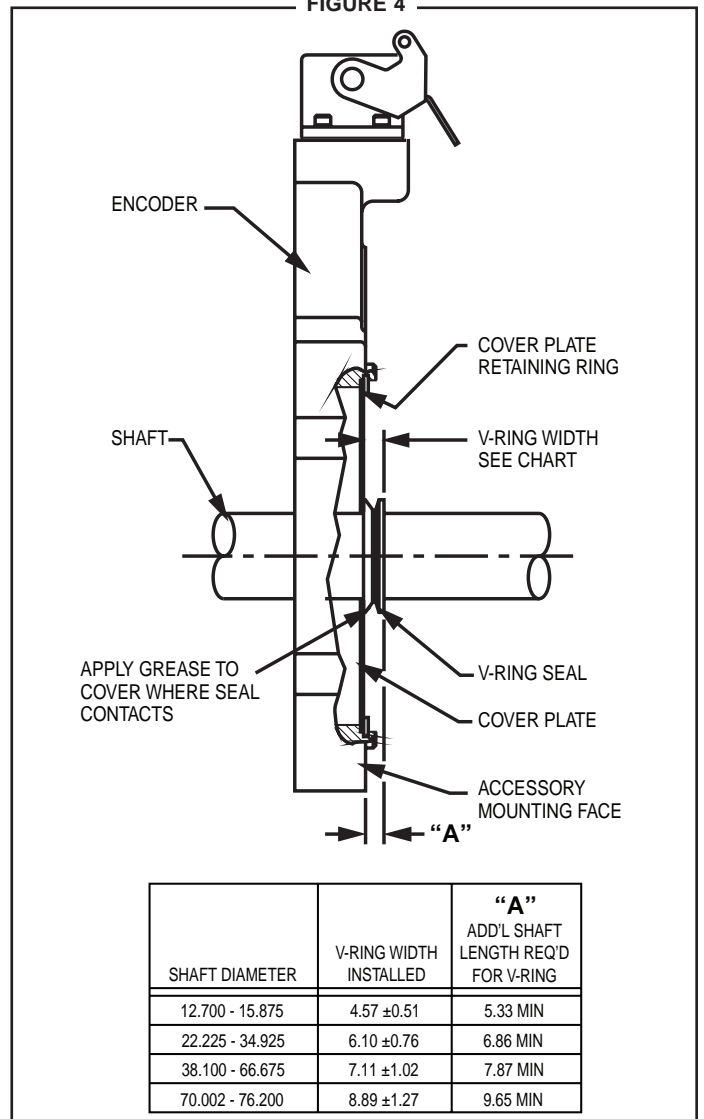

FIGURE 4



## COVER INSTALLATION

Covers must not interfere with the motor shaft or rotor. The longest shaft that can be used without interfering is 17.5mm with a standard flat cover (Cover Style option "F") and 63.5mm with an extended "pie pan" cover (Cover Style option "E"). Through shaft covers with seals are available for other applications (Cover Style option "T").

## EXTENDED COVER MOUNT (Cover Style option "E")

The extended cover mounts to the encoder housing using quantity 4 #6-32 x 0.31" screws, lock washers, and thread locker.

## THRU SHAFT AND FLAT COVER INSTALLATION

(Cover Style option "T" and "F")

The housing has a machined step in the outboard face to accept the cover and a recessed groove for the retaining ring. Insert the cover, line up ears on cover, smooth side facing out, fully into the machined step until it seats against shoulder. Using a spiral assembly method, install the retaining ring by first inserting the squared off end into the machined groove. Flex the ring and insert it into the groove walking it around the perimeter (A flat blade screwdriver can be used). Final position should have the ring fully seated into groove. Remove the cover by reversing above procedure, starting with the tang end.

## V-RING INSTALLATION FOR THRU SHAFT COVERS

(Cover Style option "T")

For thru shaft covers, verify that the shaft passes completely through the hole in the cover. Apply a small amount of silicone lubricant to the cover plate around the thru shaft hole. The V-Ring seal should compress axially when it is pressed against the clean, smooth face of the cover plate. See Figure 4 for proper installation and V-Ring compression.

## WIRING

### CAUTION

**Be sure to remove power before wiring the encoder. Be sure to ground the cable shield: It can be connected to case ground at the encoder, or grounded as the receiving device, but should not be grounded on both ends. See note below for Danaher/Northstar wiring.**

Refer to the wiring diagrams for specific information on each option.

The AV115 can be wired for single phase or two phase, either with or without complements, with or without markers. For bidirectional operation, Phase A channel leads phase B channel for clockwise shaft rotation as viewed from the anti-drive or accessory end of the motor (AV115 mounting end).

### NOTE

**Wiring option "G" provides a pinout compatible with Northstar™ encoders, with a cable shield connection on pin 10. Note that this option does not ground the shield; Avtron still recommends grounding the shield at the drive end of the cable for all wiring options.**

## CORRECTIVE ACTION FOR PHASE REVERSAL

- 1) Remove Power.
- 2) Exchange wires on cable, either at encoder cable end, or at speed controller end (but not both).
  - a) **Single Ended 2 Phase Wiring** (see wiring diagram)  
Exchange A and B at the use end of the wires.
  - b) **Differential 2 Phase Wiring** (see wiring diagram)  
Exchange **either** A with  $\bar{A}$  in the phase A pair **OR** B with  $\bar{B}$  in the phase B pair but **NOT** both.
- 3) Apply Power.
- 4) Verify encoder feedback is correct, using hand rotation of shaft, or jog mode of the speed controller.

Interconnecting cables specified in the wire selection chart are based on typical applications. Physical properties of cable such as abrasion, temperature, tensile strength, solvents, etc., are dictated by the specific application. General electrical requirements are: stranded copper, 22 through 16 AWG (Industrial EPIC connector type options can use 14 AWG), each wire pair individually shielded with braid or foil with drain wire, .05 uf of maximum total mutual or direct capacitance, outer sheath insulator. See specifications for maximum cable length. Stranded 22 AWG wire should not be used for cable runs greater than 61 meters. If 22 AWG is used with EPIC type connector options the wire ends should be tinned.

## FAULT-CHECK

After power-up and the rotor position is checked by the sensor, the Fault-Check LED will turn green.

If the adaptive electronics reach their adjustment limit for any reason, the Fault-Check alarm and LED will notify the drive and operator of an impending failure. The LED will turn red if the Adaptive Electronics reach their adjustment limit. This output occurs before an actual failure, allowing steps to be taken to replace the unit before it causes unscheduled downtime. Fault-Check annunciation is available as an "alarm" output through the connector and as an integral LED.

## TROUBLESHOOTING

If the drive indicates a loss of encoder/tach fault and the AV115 fault-check LED is not illuminated, check the encoder power supply. If power is present, check polarity; one indicator of reversed power supply is that all outputs will be high at the same time. If the drive indicates encoder fault, but the LED shows GREEN, then check the wiring between the drive and the encoder. If the wiring appears correct and in good shape, test the wiring by replacing the AV115. If the new unit shows GREEN, and the drive still shows encoder loss/tach fault, then the wiring is faulty and should be repaired or replaced.

If the alarm output and/or LED indicate a fault (RED):

1. Remove the rear cover, and use the built-in gauge to check the location of the rotor (see Figure 1). Ensure the label marked "This side out" is facing away from the motor.
2. Remove the AV115 from the motor. Clean the housing mounting surface for the AV115 housing. Ensure the AV115 is directly mounted on the motor, with no sealant, gasketing, or other materials, and is firmly bolted in place.

If the alarm output and/or LED indicate a fault (RED) on a properly mounted AV115 and the rotor is properly located, replace the AV115 sensor.

## Thinline II Spare Parts (AV56/AV56S/AV67/AV85/AV115 Only)

### SAE/USA Sizes

Shaft Size	Rotors AV56A, AV67, AV85, AV115			Rotor AV56S	Thru-Shaft Covers		
	Option Code	Cam Screw	Set Screw	Set Screw Stainless Rotor	AV56, AV56S, AV67 & AV115 Cover Kit	AV85 Cover /kit	Seal Only
.500/.4995	CA	AVTR1-CA	N/A	AVTR2-TA	A36521-TA	A36523-TA	471960
.625/.6245	CB	AVTR1-CB	N/A	AVTR2-TB	A36521-TB	A36523-TB	471877
.875/.8745	CC	AVTR1-CC	N/A	AVTR2-TC	A36521-TC	A36523-TC	471963
.9375/.9370	CD	AVTR1-CD	N/A	AVTR2-TD	A36521-TD	A36523-TD	471963
1.000/.9995	CE	AVTR1-CE	N/A	AVTR2-TE	A36521-TE	A36523-TE	471964
1.125/1.1245	CF	AVTR1-CF	N/A	AVTR2-TF	A36521-TF	A36523-TF	471965
1.250/1.2495	CG	AVTR1-CG	N/A	AVTR2-TG	A36521-TG	A36523-TG	471967
1.375/1.3745	CH	AVTR1-CH	N/A	AVTR2-TH	A36521-TH	A36523-TH	471952
1.500/1.4995	CT	AVTR1-CT	N/A	AVTR2-TT	A36521-TT	A36523-TT	471969
1.625/1.6245	CJ	AVTR1-CJ	N/A	AVTR2-TJ	A36521-TJ	A36523-TJ	471969
1.750/1.7495	CK	AVTR1-CK	N/A	AVTR2-TK	A36521-TK	A36523-TK	471970
1.875/1.8745	CL	AVTR1-CL	N/A	AVTR2-TL	A36521-TL	A36523-TL	471970
2.000/1.9995	CM	AVTR1-CM	N/A	AVTR2-TM	A36521-TM	A36523-TM	471971
2.125/2.1245	CN	AVTR1-CN	N/A	AVTR2-TN	A36521-TN	A36523-TN	471972
2.250/2.2495	CQ	AVTR1-CQ	N/A	AVTR2-TQ	A36521-TQ	A36523-TQ	471972
2.375/2.3745	CP	AVTR1-CP	N/A	AVTR2-TP	A36521-TP	A36523-TP	471953
2.500/2.4995	CR	AVTR1-CR	N/A	AVTR2-TR	A36521-TR	A36523-TR	471954
2.625/2.6245	TS	N/A	AVTR1-TS	AVTR2-TS	A36521-TS	A36523-TS	471954
2.875/2.8745	TU	N/A	AVTR1-TU	AVTR2-TU	A36521-TU	A36523-TU	471956
3.000/2.9995	TV	N/A	AVTR1-TV	AVTR2-TV	A36521-TV	A36523-TV	471956
3.1250/3.1245	T4	N/A	AVTR1-T4	AVTR2-T4	A36737-T4	A36523-T4	471957
3.1875/3.1870	T7	N/A	AVTR1-T7	AVTR2-T7	A36737-T7	A36523-T7	471957

1.125" w/.25" Keyway	B33334-2	B29787
15/16" w/.25" Keyway	B33334-1	B31033

### Extended and Flat Cover Plates

Shaft Size	Model	Extended Shaft Cover Kit	Flat Cover Kit
Any	AV56A, AV67, AV115	A35841	A37298
Any	AV56S	A36526	A37298
Any	AV85	A35841	A36525

## Thinline II Spare Parts (AV56/AV56S/AV67/AV85/AV115 Only)

### Metric Sizes

Shaft Size	Rotors AV56A, AV67, AV85, AV115			Thru-Shaft Covers		
	Option Code	Cam Screw	Set Screw	AV56, AV56S, AV67 & AV115 Cover Kit	AV85 Cover /kit	Seal Only
10mm	D2	AVTR1-D2	N/A	A36522-M2	A36524-M2	471959
11mm	DA	AVTR1-DA	N/A	A36522-MA	A36524-MA	471959
12mm	D3	AVTR1-D3	N/A	A36522-M3	A36524-M3	471960
14mm	DB	AVTR1-DB	N/A	A36522-MB	A36524-MB	471961
15mm	DC	AVTR1-DC	N/A	A36522-MC	A36524-MC	471961
16mm	DD	AVTR1-DD	N/A	A36522-MD	A36524-MD	471877
18mm	D4	AVTR1-D4	N/A	A36522-M4	A36524-M4	471962
19mm	DE	AVTR1-DE	N/A	A36522-ME	A36524-ME	471951
24mm	DF	AVTR1-DF	N/A	A36522-MF	A36524-MF	471964
28mm	DG	AVTR1-DG	N/A	A36522-MG	A36524-MG	471965
30mm	DH	AVTR1-DH	N/A	A36522-MH	A36524-MH	471966
32mm	DT	AVTR1-DT	N/A	A36522-MT	A36524-MT	471967
36mm	DJ	AVTR1-DJ	N/A	A36522-MJ	A36524-MJ	471968
38mm	DK	AVTR1-DK	N/A	A36522-MK	A36524-MK	471969
42mm	DL	AVTR1-DL	N/A	A36522-ML	A36524-ML	471969
45mm	DM	AVTR1-DM	N/A	A36522-MM	A36524-MM	471970
48mm	DN	AVTR1-DN	N/A	A36522-MN	A36524-MN	471971
52mm	DP	AVTR1-DP	N/A	A36522-MP	A36524-MP	471971
55mm	DR	AVTR1-DR	N/A	A36522-MR	A36524-MR	471972
60mm	DS	AVTR1-DS	N/A	A36522-MS	A36524-MS	471953
65mm	MU	N/A	AVTR1-MU	A36522-MU	A36524-MU	471954
70mm	MV	N/A	AVTR1-MV	A36522-MV	A36524-MV	471955
75mm	MW	N/A	AVTR1-MW	A36522-MW	A36524-MW	471956
80mm	MY	N/A	AVTR1-MY	A36737-MY	A36524-MY	471957
85mm	MZ	N/A	AVTR1-MZ	A36737-MZ	A36524-MZ	471958

### Extended and Flat Cover Plates

Shaft Size	Model	Extended Shaft Cover Kit	Flat Cover Kit
Any	AV56A, AV67, AV115	A35841	A37298
Any	AV56S	A36526	A37298
Any	AV85	A35841	A36525

**NOTE:**

Do not use rotors from THIN-LINE I (M56, M56S, M67, M85, M115) with AV115. This will cause incorrect PPR output, but the AV115 LED will remain green.

**ENCODER REMOVAL**

The AV115 stator housing can be removed by loosening and removing the socket head cap screws.

**CAM SCREW ROTOR REMOVAL**

Disengage the (2) cam screws by turning them counterclockwise less than 1 full turn. The cam heads will visibly move away from the shaft. Remove the rotor by hand by pulling it away from the motor. If the rotor will not move, do NOT use a gear puller, and do not use a heat gun. Instead, insert two M6 screws, >25mm length into the Jack Screw Holes shown in Fig 2. Alternately tighten the screws to push the rotor away from the motor and remove it.

**LARGE BORE SET SCREW ROTOR REMOVAL**

Disengage the (2) set screws by turning them counterclockwise until removed from the rotor. Retain the set screws. Remove the rotor by hand by pulling it away from the motor. If the rotor will not move, do NOT use a gear puller, and do not use a heat gun. Instead, pry the rotor away from the motor gently, being careful to only pry against the rotor metal hub and not the magnetic outer strip.

CONNECTOR SPARE PARTS					
STYLE	OPTION CODE	ENCODER SIDE		CABLE SIDE PLUG	
Industrial EPIC on Encoder	P,G	315233	Base	315231	Hood
		315229	Terminal	315230	Terminal
Industrial EPIC w/ Adapter Block	Q			401112	Adapter
Industrial EPIC on 3' Cable	Z	315232	Surface	315231	Hood
		315229	Terminal	315230	Terminal
		471819	Bushing	401112	Adapter
Mini-MS Twist Lock	R, S	315296	Base	316110	Plug
10 pin MS on cable	Y	314383	In-Line	315932	Plug
				411216	Cable Bushings
				411217	
				411218	
				411219	

## WIRING DIAGRAMS

### FOR DIFFERENTIAL APPLICATIONS

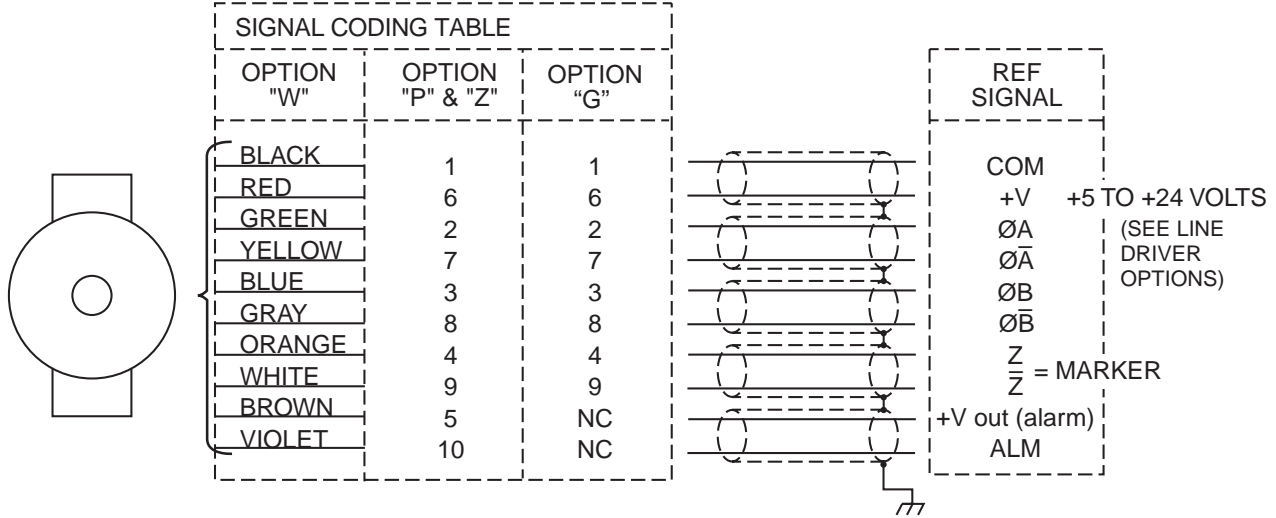

### FOR SINGLE ENDED TWO PHASE APPLICATIONS

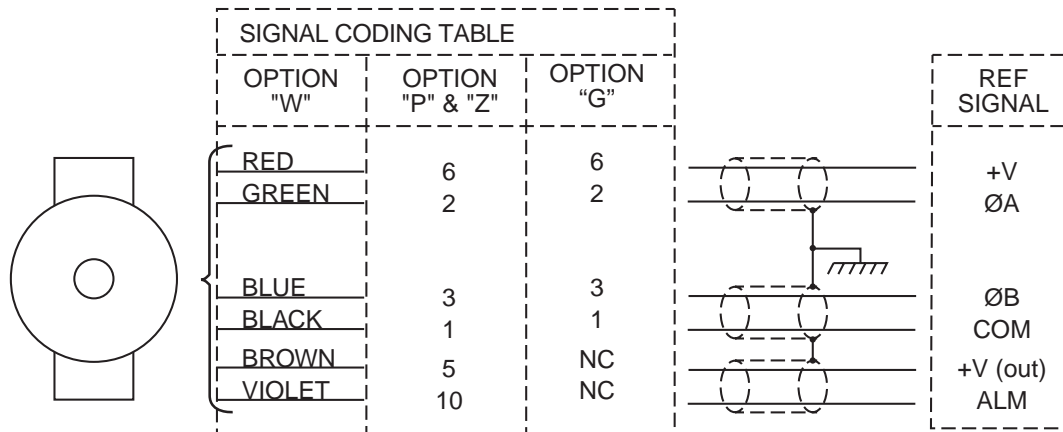

### FOR SINGLE ENDED SINGLE PHASE APPLICATIONS

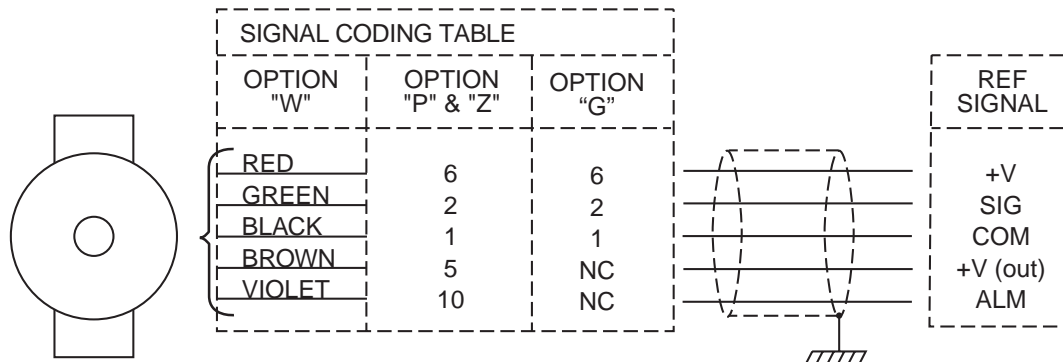

**TYPICAL WIRE SELECTION CHART**  
for 18 AWG, multiple pair, individually shielded

	BELDEN	ALPHA
2 PAIR	9368	5620B1802
3 PAIR	9773 or 9369	6445
4 PAIR	9388	6444
3 CONDUCTOR	9365	5640B1801

For option "W", unused outputs must be insulated to prevent accidental contact.

**NOTE:** Avtron standard 3 year warranty applies. Copies available upon request. Specifications subject to change without notice.

# THIN-LINE II™

## Application Examples

Applies to all model AV115 encoders, except for wiring option "G".

### ALARM OUTPUT CONNECTION

Avtron THIN-LINE II encoders provide an alarm signal if maintenance is required under specific circumstances. An optional internal alarm LED indicator is also available. Green indicates power on, red indicates alarm on. Following are application examples provided to help install the alarm output.

Example 1. Alarm output using +V(OUT). +V(OUT) is equal to +V, the encoder power supply.

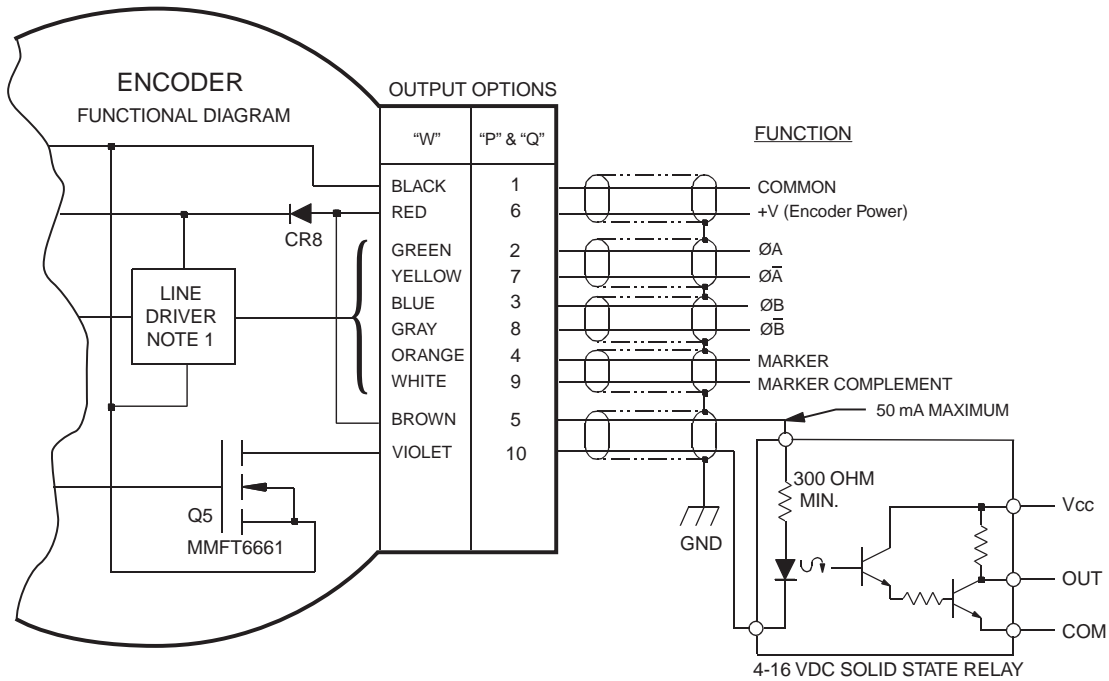

Example 2. Alarm Output Using Separate 24 VDC Power Supply and Relay.

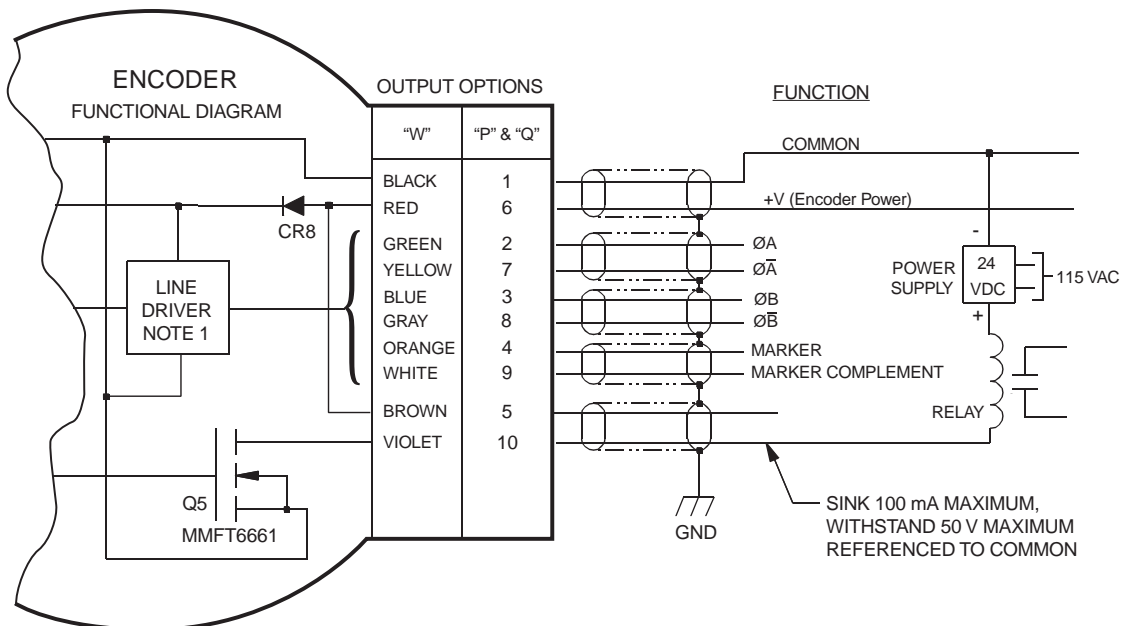

# OUTLINE DRAWING

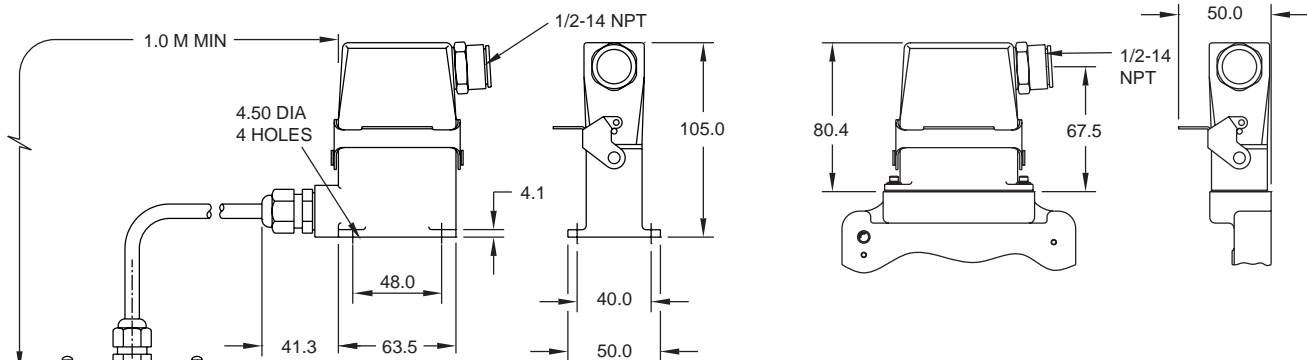
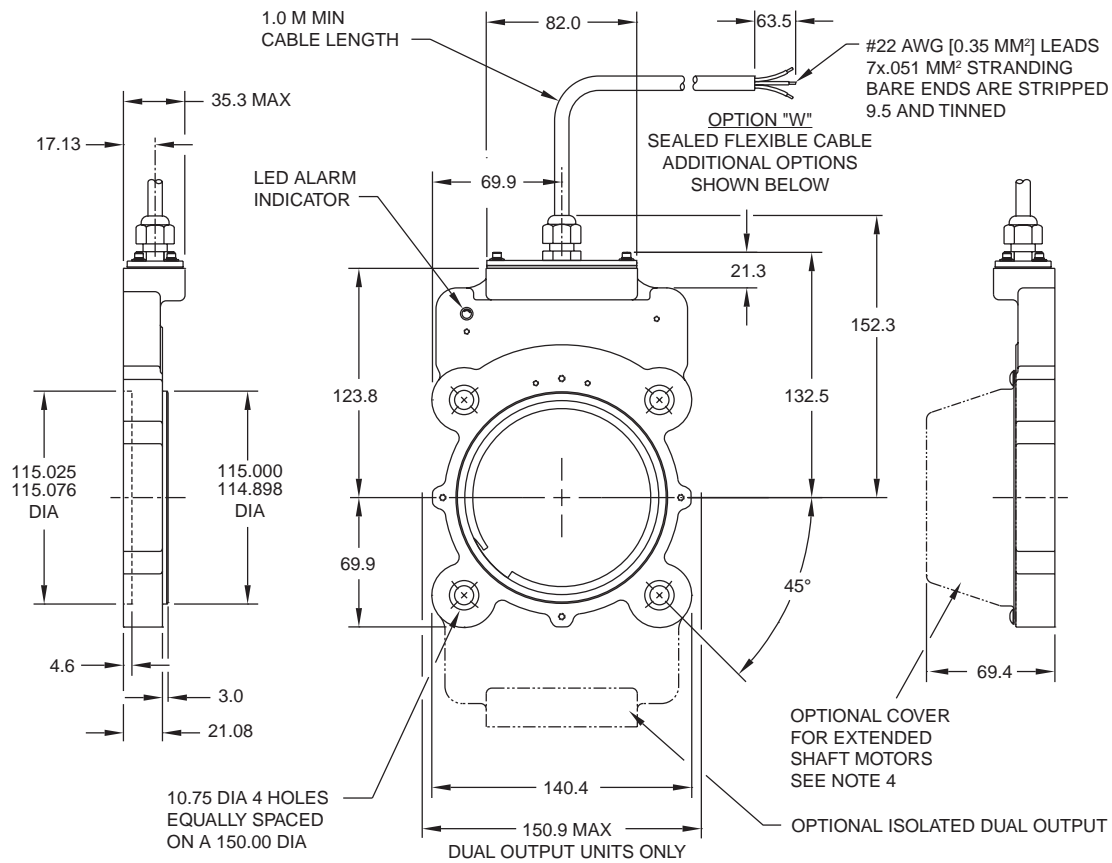

OPTION "Z"  
SURFACE MOUNTED PLUG-IN  
INDUSTRIAL CONNECTOR

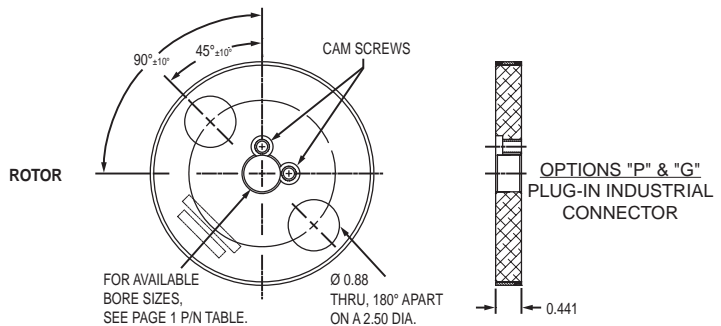

- 4 - STANDARD FLAT COVER SHOWN IN FRONT VIEW. OPTIONAL THRU-SHAFT COVER NOT SHOWN
  - 3 - DIMENSIONS IN MILLIMETERS
  - 2 - ALL DIMENSIONS ARE APPROXIMATE
  - 1 - WEIGHT: 0.9 TO 1.36 KG.
- NOTES:

CE Pending

Features and specifications subject to change without notice.  
Avtron standard warranty applies. All dimensions are in millimeters approx.

